

NOTES:

1. AERATOR MODEL 665 OR 700LL MUST BE USED IN CONTINUOUS OPERATION.
2. MAXIMUM BURIAL DEPTH 48" FROM TOP OF TANK.
3. UV DISINFECTION UNIT IS JET MODEL 952.
4. PUMP TANK AERATION IS PROVIDED BY HIBLOW HP-40 COMPRESSOR OR EQUAL.
5. PUMP FLOAT SET TO LIMIT WATER IN PUMP TANK TO 280 GALLONS. SEE TABLE FOR DIMENSIONS.
6. MUST USE CONTROL PANEL WITH WITH PUMP/ALARM INTERLOCK RELAY.
7. DIFFUSER MUST BE 12" BELOW PUMP ACTIVATION LEVEL.
8. SAMPLE PORT MUST BE PLACED IN EFFLUENT LINE. USE 12" D-BOX OR EQUIVALENT,

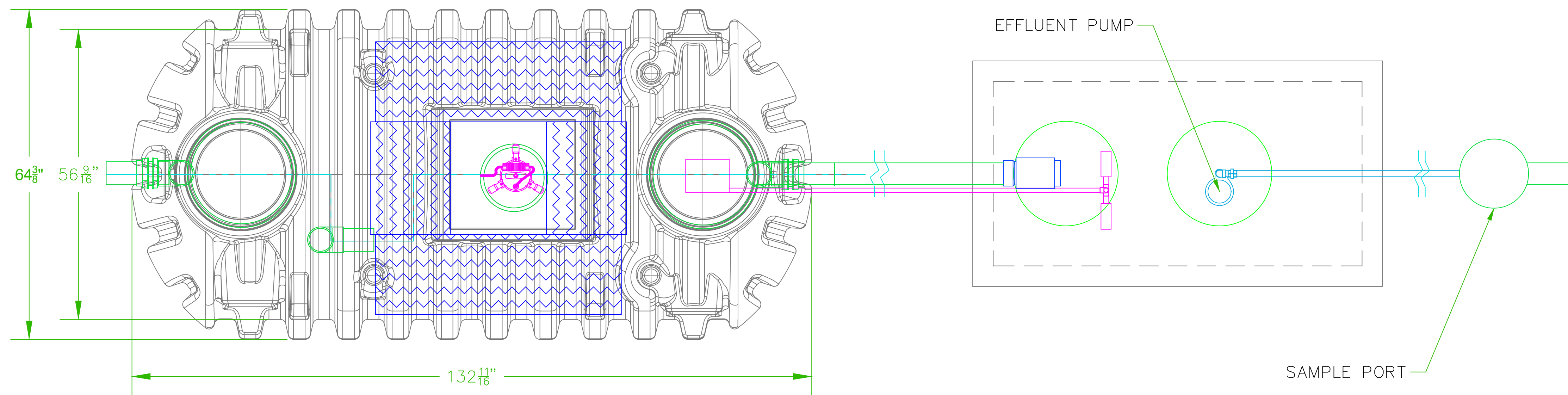

MAXIMUM PUMP FLOAT HEIGHT	
TANK CAPACITY (GAL/INCH)	HEIGHT (INCHES)
OVER 20	12 3/4"
20	14"
18	15 1/2"
16	17 1/2"
15	18 1/2"
14	20"
13	21 1/2"
12	23 1/4"
11	25 1/2"
10	28"

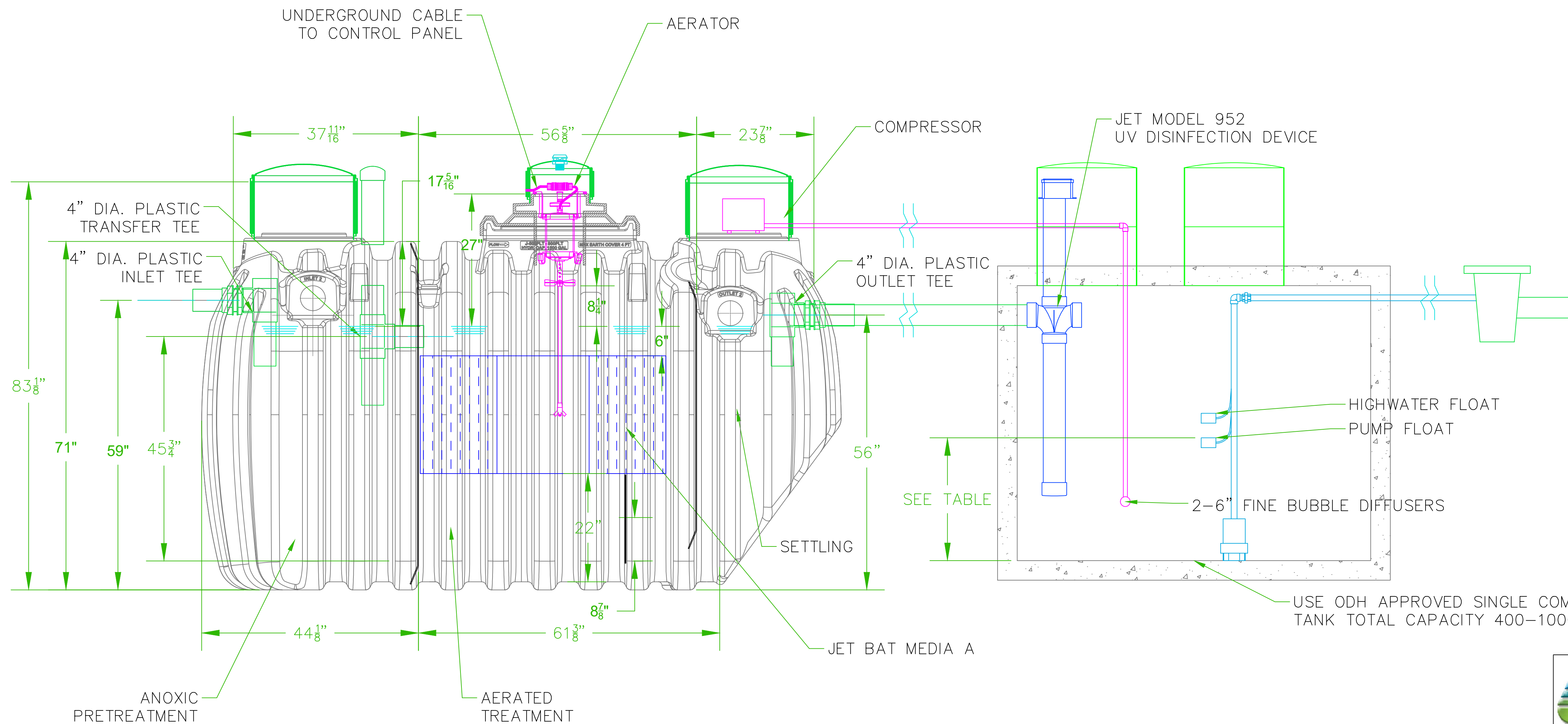

USE ODH APPROVED SINGLE COMPARTMENT TANK ONLY  
TANK TOTAL CAPACITY 400-1000 GALLONS



TITLE:  
J-800 WITH EFFLUENT PUMP  
TANK  
UPGRADE

USED ON:

PROPRIETARY PROPERTY: THIS DRAWING IS THE PROPERTY OF JET INC. AND MAY NOT BE REPRODUCED, COPIED OR USED WITHOUT WRITTEN PERMISSION.

DRAWN BY: BHD  
DATE: 8/1/2024

APPROVED BY: DATE:

MATERIAL:

SCALE: 1 : 20  
SIZE: C

UNLESS OTHERWISE SPECIFIED:  
ALL DIMENSIONS ARE IN INCHES  
DECIMAL: ± .005  
FRACTIONAL: ± 1/64  
DEGREE: ± 1'

DRAWING NUMBER:  
J-800-PLT PTR  
REV: -